

# KD300 ELECTRICAL THRUSTER.

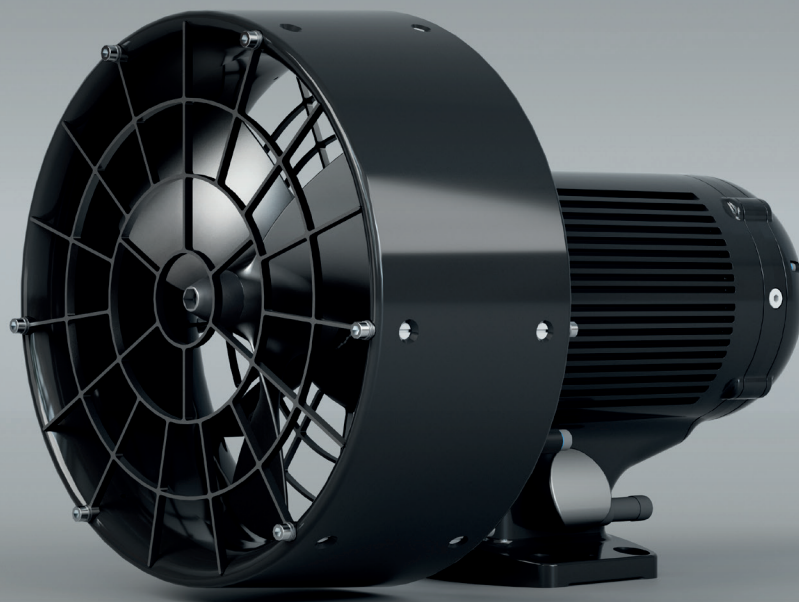

20 kW



Engineered for 24/7 operation for up to 30 days without intervention. Our electric thruster delivers relentless power and durability and sets a new standard for efficiency and environmental consciousness. Featuring an integrated pressure-tolerant power inverter, fully isolated design, and dual rotary shaft seals, it exemplifies our dedication to cutting-edge engineering.

## KEY FEATURES

- Compact design
- Powerful
- Built-in pressure tolerant power inverter
- Fully isolated design
- Supports many operation modes: speed, torque & position
- Efficient and flexible protocol
- Built-in diagnostics
- Dual rotary seal with shaft seal flushing option
- Built-in line cutter
- Hard anodized aluminum housing

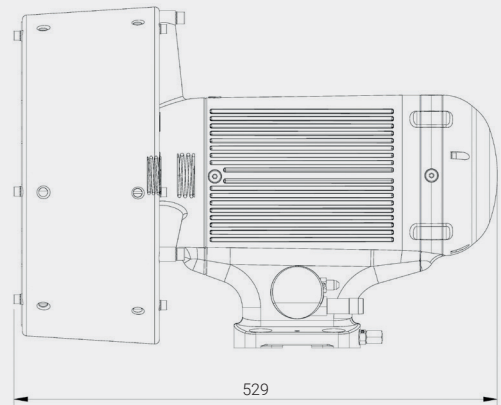

## SPECIFICATIONS

Information:	
Power	20 kW nominal / 30 kW peak
Depth rating	3000 msw
Weight in air	43 kg
Weight in water	31 kg
Input voltage, control	24 VDC
Communication	Ethernet (Optional RS-422)
Input voltage, motor	800 VDC nominal / 1000 VDC max

All technical data and specification are subject to change 2024-03

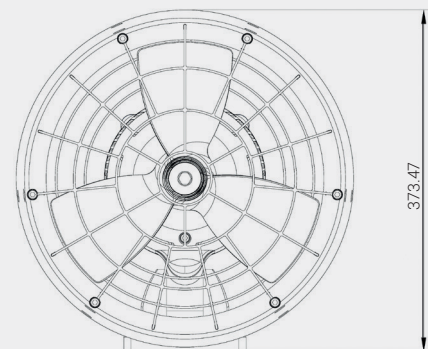

1:5

