

SUBSEA WORM GEAR

- SIZE A53

The worm gear is a compact unit designed for applications where a controlled rotational movement is required.

The unit is pressure compensated for use at full ocean depth.



SPECIFICATION:

- **Nominal Torque:** 80Nm @82 bar start, 62 bar continuous
- **Rpm:** 8.5 rpm @ 1 l/min, max rpm 136 @16 l/min.
- **Max Operation Pressure:** 100 bar
- **Dry weight:** 7 kg (incl. oil)
- **Submerged weight:** 5.2 kg
- **KD Drg. Ref.:** AG47-1000M01

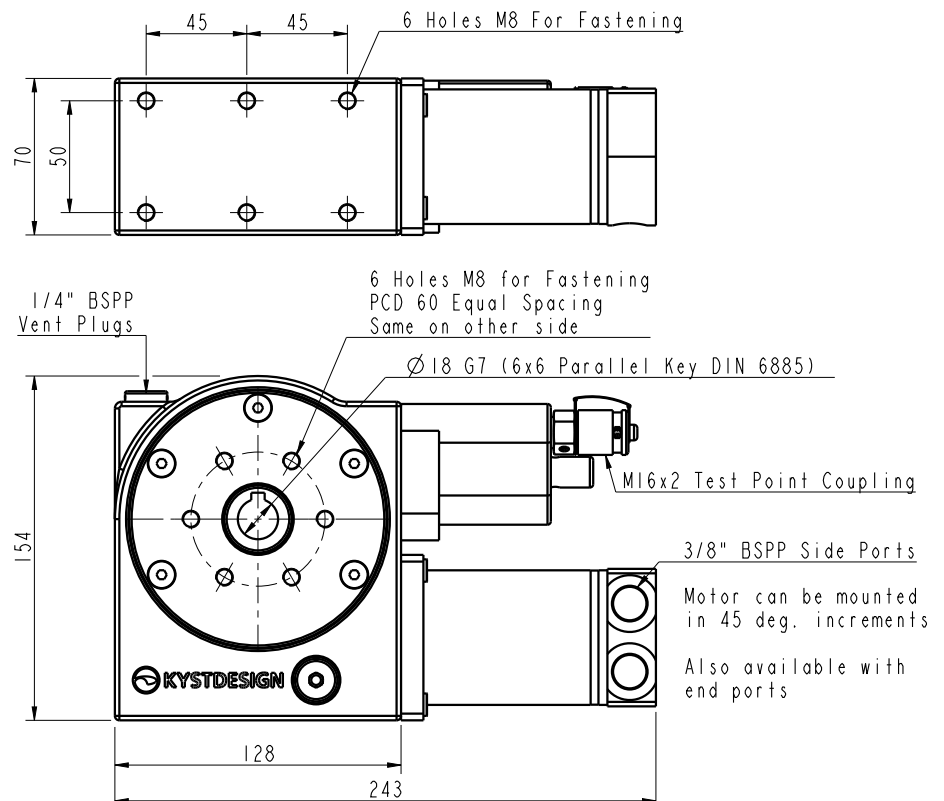

KYSTDESIGN AS

Eikeskogvegen 80 - 5570 Akسدal, Norway
post@kystdesign.no - Phone: +47 52 70 62 50

www.kystdesign.no