

# KPA-45-I PAN UNIT

For high payload applications down to 1000m water depth



**KPA-45-I**  
Single axis - Internal compensator

## KEY FEATURES

- Single axis unit with internal compensator
- Rugged construction and mounting holes
- High torque – heavy payloads can be added
- 90 or 120 Nm units
- RS-232, RS-485 or 100 Mbps Ethernet
- Absolute position sensor
- $\pm 0.1$  deg accuracy;  $\pm 0.01$  deg on request
- 24 to 48 VDC input voltage range
- No rotating connector at unit
- Max depth 1,000 Meter (3,000 ft)

The KPA-45-I with its rugged design and internal compensator is designed for continuous hard work.

Equipped with absolute position sensors there is no need to find end-stops at start-up.

Easy to check functionality of compensator and refilling.

# KPA-45-I SPECIFICATIONS

## Electrical:

Input Voltage	24-48 VDC
Drive Current	Up to 2.5 A
Communication	RS-232, RS-485 (2 wire) or 100 Mbps Ethernet (down to 1000m, 3000 ft)
Connector	Customer selectable (Seacon 5 pin standard)

## Mechanical:

Angular Limits	Pan range: $\pm 175^\circ$
Angular Speed	Up to 30 deg/sec
Torque @24VDC, performance at 48VDC even better	90 Nm holding torque *) - 75 Nm (55 lb/ft) < 8 deg/sec - 60 Nm (44 lb/ft) < 15 deg/sec - 45 Nm (33 lb/ft) up to 20 deg/sec
Max Payload **	100 kg (220 lbs)
Position Feedback	12 bit accuracy absolute, approx. $\pm 0.1^\circ$ 15 bit $\pm 0.01^\circ$ on request
Gears	Precision strain wave
Backlash	< 3 arc minutes (< 0.05°)
Compensator	Internal oil filled diaphragm

## Environmental:

Operating Depth	Down to 1000 m (3,000 ft.) as the volume of the compensator is not big enough to compensate for pressure and temperature changes for bigger depths.
Temperature Range	-20°C to +50°C (-4°F to +122°F) operating -30°C to +60°C (-22°F to +140°F) storage

## Others:

Size (H/W/D)	195 x 114 mm (Flange $\varnothing 157.5$ mm) 7.48 x 4.49 inch (Flange $\varnothing 5.62$ inch)
Materials	Hard anodized Aluminum or Titanium
Weight in Air	4.7 kg (10.4 lbs) (Aluminum unit)
Weight in Water	2.8 kg (6.2 lbs) (Aluminum unit)

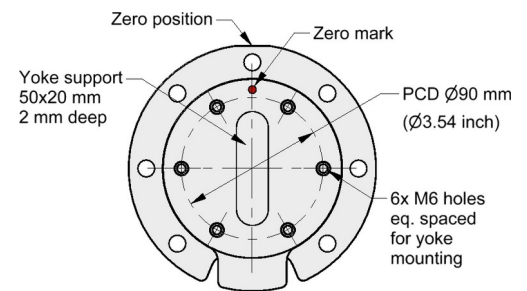
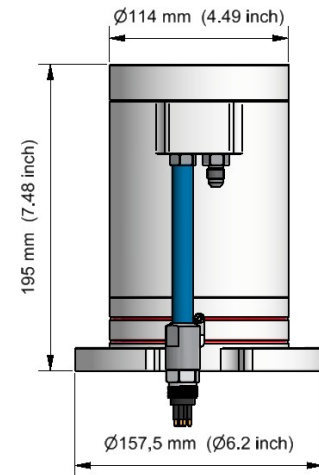

## Mounting holes (bottom view)

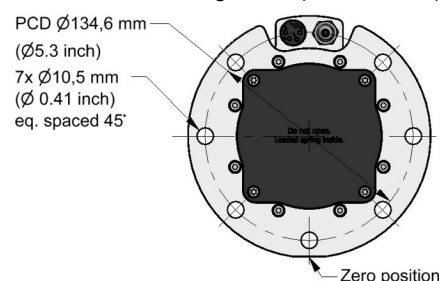

\*) 120 Nm unit available with different gear ratio

\*\*) Payload Torque diagram (in air)

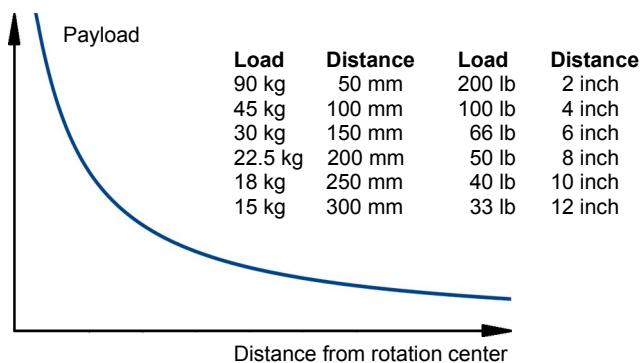

## KYSTDESIGN AS

Eikeskogvegen 80 - 5570 Aksdal, Norway  
post@kystdesign.no - Phone: +47 52 70 62 50

www.kystdesign.no