

1

2

3

4

5

6

A

A

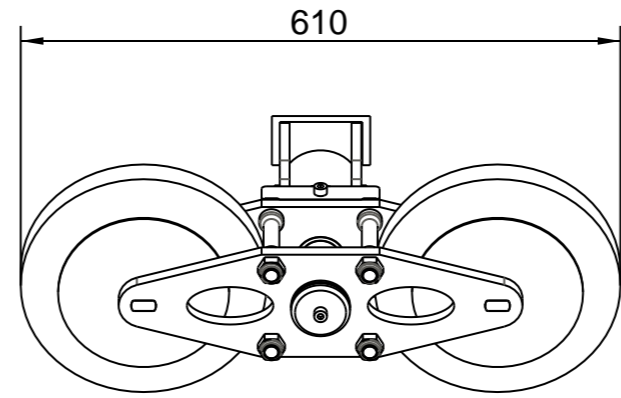
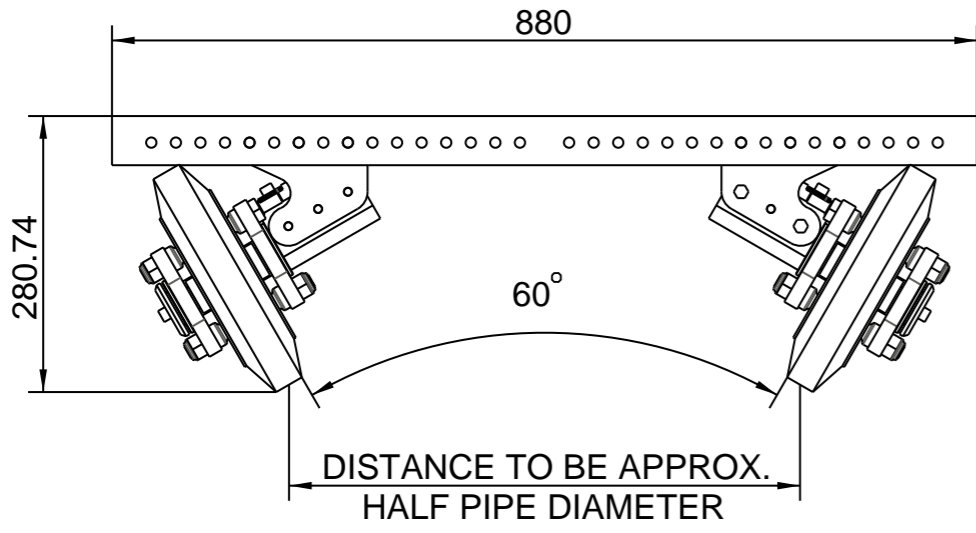

B

B

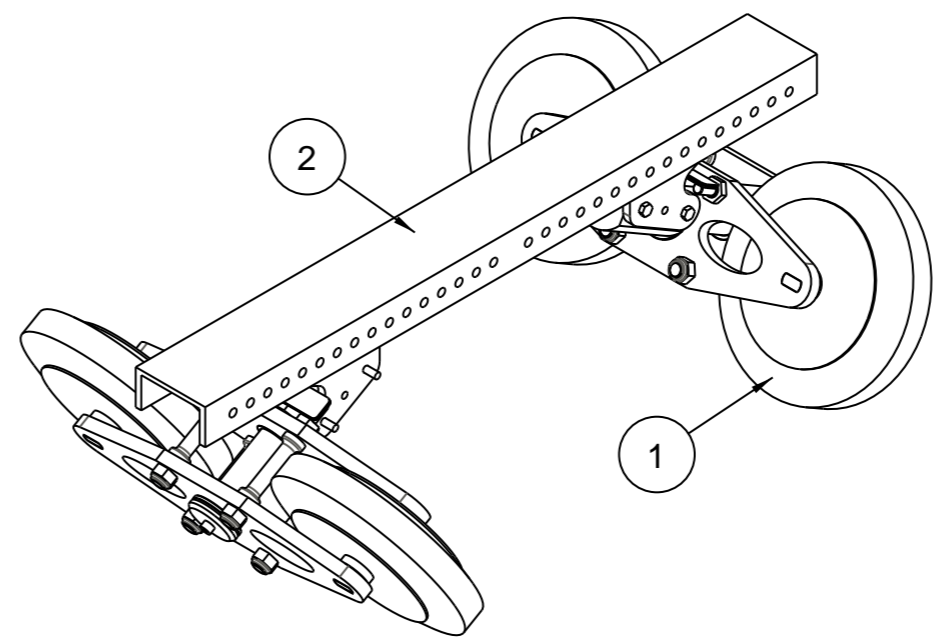
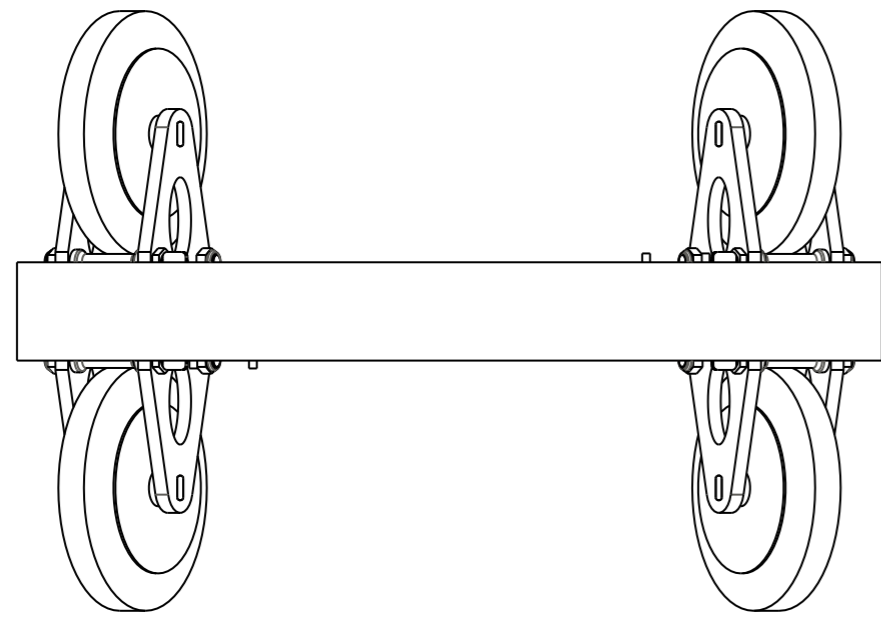

Dry Weight: 27,8 KG

in the information contained therein. Reproduction, use or disclosure to third parties without consent is strictly forbidden.
 KYSTDESIGN AS

C

C

Itm.	Qty.	Description	Drg. / Spec.	Material
5	12	M10 WASHER	DIN125A	A4
4	6	M10 LOCKNUT	DIN985	A4
3	6	M10x120	DIN912	A4
2	1	BOGGI MOUNTING BRACKET	SHEET 4	
1	2	BOGGI ASSEMBLY	SHEET 2	

Rev.	Date	Description	Prep	Chk	App
01	25.04.02	ISSUED FOR PRODUCTION	AHO	EKB	PGE
A	22.04.02	ISSUED FOR COMMENTS	AHO	EKB	PGE

D

D



Drawing title PIPERIDING BOGGI SOLO Mk2 ASSEMBLY		
KYSTDESIGN AS Strandgaten 202, 5525 Haugesund, NORWAY Tel: +47 52 70 62 50 Fax: +47 52 70 62 01 www.kystdesign.no		Scale 13:100
File name AB12-DR004		Sheet 1 of 4

1

2

3

4

5

6